

# DEFLECTION OF PLATES BY FLOW CHANNEL DISPARITIES IN RESEARCH REACTOR FUEL

C. BOJANOWSKI<sup>1</sup>, G.L. SOLBREKKEN<sup>2</sup>, G.H. SCHNIEDERS<sup>2</sup>, J.D. RIVERS<sup>2</sup>,  
A.M. TENTNER<sup>1</sup>, E.H. WILSON<sup>1</sup> AND L.P. FOYTO<sup>2</sup>

<sup>1</sup>*Nuclear Engineering Division, Argonne National Laboratory  
9700 S. Cass Ave, Argonne, IL 60439, USA*

<sup>2</sup>*University of Missouri-Columbia  
1513 Research Park Drive, Columbia, MO 65211*

## ABSTRACT

As a part of the work supporting the Preliminary Safety Analysis Report (PSAR) submitted to the NRC by the University of Missouri Research Reactor (MURR), the impact of LEU fuel plates that are thinner (1.12 mm) compared to the HEU (1.27 mm), has been assessed. Plate deflection can arise due to velocity-induced pressure differentials between coolant channels with different thickness. Experiments were conducted on relevant MTR-type reactor plate geometries in a water flow test loop. The deflections of the plates were measured using laser displacement sensors. High-fidelity 3D simulations of the experiments were performed using several multi-physics simulation codes. When the as-built geometry of the plates was used in simulations, the predicted plate deflections were in good agreement with measured deflections. Application of the validated computational methodology to the prototypic MURR LEU plate predicts a small plate deflection under nominal flow conditions on the order of 5 micrometers, which is far less than allowances in the PSAR for change in coolant channel thickness.

## 1 Introduction

### 1.1 General Background

MURR is one of five U.S. high-power research and test reactors that currently use highly-enriched uranium (HEU). The primary objective of the Office of Material Management and Minimization (M<sup>3</sup>) is to minimize, and when possible, eliminate weapons-usable nuclear materials around the world. The U.S. High Performance Research Reactor (USHPRR) Conversion Program, as part of M<sup>3</sup>, supports the conversion of nuclear research and test reactors from the use of highly-enriched uranium (HEU) to low-enriched uranium (LEU).

The testing and analyses needed to qualify LEU fuel for MURR have two major components: 1) irradiation testing of the new fuel including a Design Demonstration Experiment (DDE) of the proposed MURR LEU fuel element conducted by the Fuel Qualification pillar of the fuel US High-Power Research Reactor (USHPRR) Conversion Program, and 2) flow tests planned in the Oregon State University Hydro-Mechanical Fuel Test Facility (OSU-HMFTF) conducted by the USHPRR Reactor Conversion pillar. Both of these efforts rely on construction of full-size MURR LEU fuel assemblies by the USHPRR Fuel Fabrication pillar. However, in advance of when full elements are available for flow testing, plate-level experiments and modeling have been performed to establish the performance of thinner LEU MURR fuel plates. The experimental work in support of MURR conversion was performed at the University of Missouri Thermal Management and Microscale Energy Conversion Research (TherM-MEC) Laboratory. The simulation work was performed at Argonne National Laboratory and University of Missouri.

For this effort, testing alone was not as effective as a broader effort including simulations because of the limited geometrical combinations that can be tested. These limitations may

arise due to the differences in manufacturing tolerances, as-built dimensions, and accuracy of measurement of quantities such as dimensions or deflection. Analysis and simulation alone without experimental measurements would also not be effective because the simulations may not include all effects, and because experimental data is needed for validation of the simulations. When simulations predict experiments accurately the reliability of results can be validated. Thus, these experiments at MU were undertaken in order to benchmark the model predictions used in the determination of safe performance of the LEU fuel elements in the MURR reactor. It should be noted that prototypic HEU fuel plates are expected to deflect so slightly that measurements of such have not generally been practical in the past. The purpose of this work is to establish prior to full element testing that deflections are not a concern in the new design of the LEU plates, which are somewhat thinner.

## 1.2 MURR Fuel Element

Each of the HEU elements consists of 24 curved fuel plates that are 64.77 cm (25.5 inch) long and span over a 45° arc (see Figure 1.1). The fueled portion of each fuel plate is 60.96 cm (24 inch) long and centered within the length of the plate. The LEU plates retain these dimensions, but there are 23 of them per element instead of 24. In order to maintain the performance of the HEU core the power is increased to 12 MW<sub>th</sub>. In the HEU element all of the fuel plates have nominal thicknesses of 1.27 mm (50 mil) for the plate, 0.508 mm (20 mil) for the fuel meat, and 0.381 mm (15 mil) for each clad, which is 6061-aluminum. The nominal spacing between HEU fuel plates is 2.032 mm (80 mil). By contrast each LEU plate has one of five nominal uranium-molybdenum (U-Mo) alloy fuel core thicknesses – 9, 12, 16, 17, or 20 mil (1 mil is equal to 0.001 inch or 0.0254 mm). The first three thicknesses apply to the inner (closest to the flux trap) three plates within an element, respectively. The plate furthest from the flux trap has a fuel core thickness of 0.432 mm (17 mil). The other 19 plates have a fuel core thickness of 0.508 mm (20 mil). All of the LEU fuel plates have a nominal thickness of 1.118 mm (44 mil) except for the one furthest from the flux trap, which has a thickness of 1.245 mm (49 mil). The fuel core thickness is centered within the plate thickness. Each LEU cladding is 6061-aluminum, except for a 0.025 mm (1 mil) thick layer of zirconium, which is an interlayer between the fuel core and cladding and serves as a diffusion barrier. The first four inner and the last four outer LEU water coolant channels that are between fuel plates have a nominal gap thickness of 2.362 mm (93 mil). The other 14 LEU coolant channels that are between fuel plates have a nominal gap thickness of 2.337 mm (92 mil). A top down view of this configuration is shown in Fig 1.1 (flow is into the page).

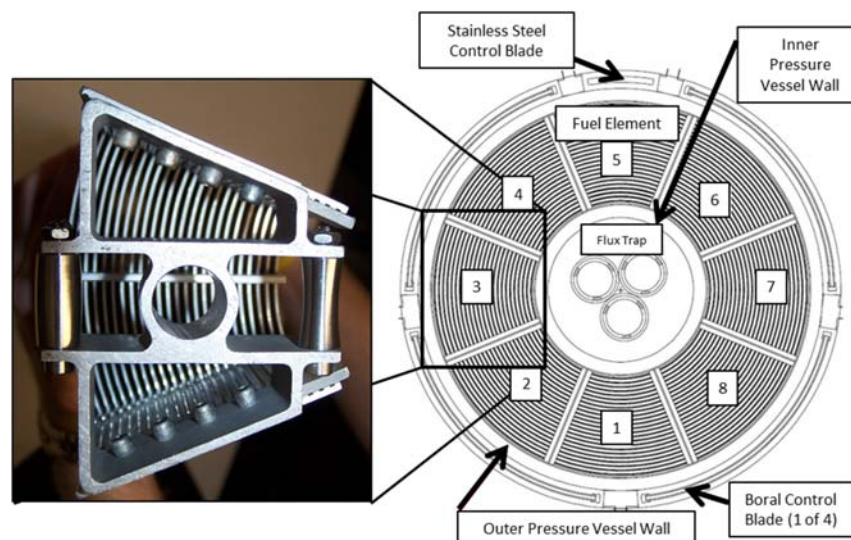

Fig 1.1. Top View of the MURR Core with Photo of a Mock Fuel Element [1].

A significant change between the HEU and LEU fuel element designs is that the thinner LEU fuel plates may make them more susceptible to bending. The tolerance on coolant channel

gap thickness between adjacent fuel plates is  $\pm 0.203$  mm ( $\pm 8$  mil) for both the HEU and LEU fuel elements. This tolerance can result in different flow velocities on either side of a fuel plate, which, in turn, can produce pressure differences from one side of the fuel plate to the other. Even with pressure differences analogous to those in the HEU fuel elements, the thinner LEU plates will lead to some level of increased plate deflection. Although plate deflection has not been observed to be a concern for HEU operations, it requires evaluation for LEU conversion in the present work.

## 2 Experimental Setup

The experimental and numerical work performed in this project pertained to both curved as well as flat plates. Although the prototypic MURR plates are curved, it was decided that the experiments will be initially performed for flat plates of similar dimensions. The flat plate experiments were performed before curved plate experiments. This was for the since flat plates and the testing rig were easier to manufacture and their deflection measurements are much easier to monitor. Additionally, the deflections of the flat plates were predicted to be significantly larger than the deflections on the curved plates of similar geometrical characteristics and thus easier to measure. This paper discusses only the work related to the curved plates as its conclusions are more relevant for the MURR conversion. However, a detailed description of all the experiments and simulations performed under this project can be found in [1] and [2].

The tests were completed at the Hydro-Mechanical Flow Loop (HMFL) at the University of Missouri. The flow loop at HMFL was designed to accommodate a wide range of test sections. The layout of the flow loop is shown in Fig 2.1. To monitor plate deflection during a flow test, two Keyence LK-G152 laser displacement sensors were used. The pressure difference between the two fluid channels during flow testing was monitored with the use of Omega PX-26 differential pressure transducers. Total water flow was measured with the use of a standard flow meter. The flow loop included a National Instruments data acquisition system for data collection and flow control. User control and monitoring was accomplished with a LabVIEW program.

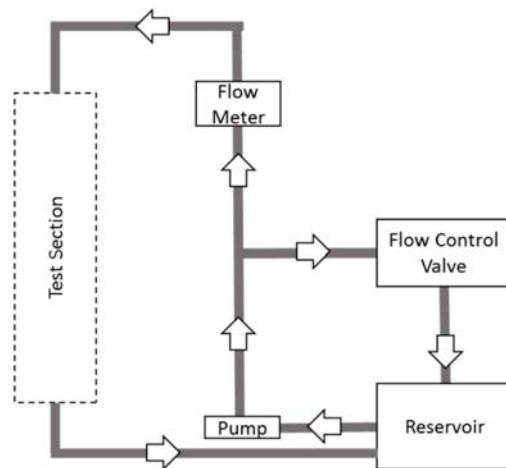

Fig 2.1. University of Missouri Hydro-Mechanical Flow Loop (HMFL) [1].

The curved duct walls for the experiment were formed between two rigid nearly concentric stainless-steel cylinders that are each about 6 mm (0.25 inch) thick (see Figure 2.2). The curved-plate experiment has five Plexiglas windows in the outer cylinder and none in the inner cylinder. It was decided that installing more or larger windows would negatively impact the stiffness of the outer cylinder. The Plexiglas allows a laser to be used to measure the position of the aluminum plate at points on the plate surface that can be observed through a window. The laser can also measure the location of the inner surface of the Plexiglas so that local water channel gap thicknesses can be inferred. The five rectangular Plexiglas windows are each 5.1-cm by 10.2-cm (2-inch by 4-inch) and have rounded corners.

Figure 2.2 on the left shows a photograph of the curved aluminum alloy 6061 test plate epoxied into two aluminum side rails and resting on the inner steel cylinder. This test plate was formed by bending a flat sheet of 26-gauge aluminum alloy (AA 6061) which is 0.404 mm (15.9 mil) thick. This thickness is not prototypic for MURR since when initial simulations were performed for a prototypic plate thickness of 1.067 mm (44 mil – 2 mil tolerance = 42 mil), the results predicted a deformation of the curved plates smaller than the ability to measure even with the advanced laser deflection method used. Thus, the approach adopted was to use a thinner than prototypic plate in the experiment to allow for model validation. In this approach, the deflections will be more pronounced and easier to measure. The simulations for the curved plate also revealed that the most critical cases are those where the thicker channel is on the inside of the plate (channel with smaller radius than the plate radius). The plate has a tendency to deflect into that thicker channel due to the pressure differential (higher pressure in the thinner channel). If the thicker channel is on the inside significantly larger deformations are expected than in the case when the thicker channel is on the outside of the curved plate.

There were 16 pressure port locations, eight on each side of the test section along the centerline of the plated region, allowing for 16 gauge measurements. Their location on the outside cylinder can be seen in Figure 2.2 on the right. The gauges were connected to differential pressure transducers between the two channels meaning that eight trans-channel pressure measurements were obtained.

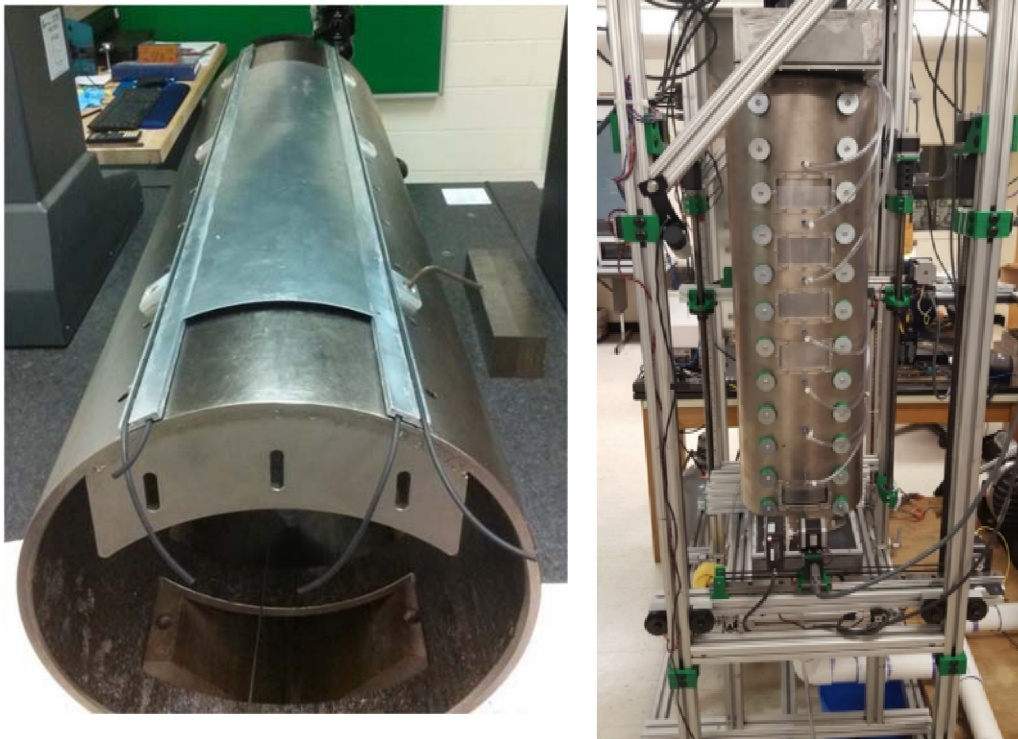

Fig 2.2. Inner Cylinder and Curved Plate Assembly (left) Curved Plate Test Section in Test Loop (right).

A laser measurement system has been used to monitor the deflections of the plate. The main challenge with laser displacement measurements in the curved section is that both the viewports and the plate are curved surfaces. For the flat test sections, the laser head can be easily positioned perpendicular to the surface at any position. However, for the curved section, the viewport is rounded. The laser beam must strike the viewport and then in turn the plate perpendicular to their surfaces so that it will reflect directly back to the sensor. If the laser beam is not perpendicular to the surfaces the reflected beam will go off at an angle away from the sensor. The laser positioning is designed to move in straight lines and therefore cannot follow

the curvature of the viewports to remain perpendicular. This leads to only being able to take accurate measurements along an axial line at the center of the plate span (width) in the viewports. However, the center of the plate span in the location of maximum deflection based on simple theory as well as through experience in the flat plate experiments, and simulations of curved plates. Thus these measurements remain the most appropriate.

The geometry of the ideal curved plate test setup is presented in Figure 2.3 and Table 2.1. It is recognized that it is not experimentally possible to exactly reproduce an ideal geometry in any plate. However, the curved test section was built, assembled, and carefully measured since, as was found to be important in the prior flat plate work, the as-built geometry was required in order to allow accurate predictions. Before the pressure taps were inserted into pressure ports, the depth between the outside of the outer cylinder of the test section and the plate was measured through the pressure ports. The thickness of the outer (thinner) channel measured with the use of that approach is presented in Figure 2.4. The thickness varies between 2.22 mm (87.5 mil) near the leading edge and 0.952 mm (37.5 mil) near the trailing edge. Shown in Figure 2.4 is the axial cross section of the assembled test section and plate. In addition to the measurements indicated, assumptions were required at the plate leading edge. Whereas the as-built measurements remain important to modeling, the assumptions regarding the position and angle of the leading edge were verified to not influence the numerical model results significantly.

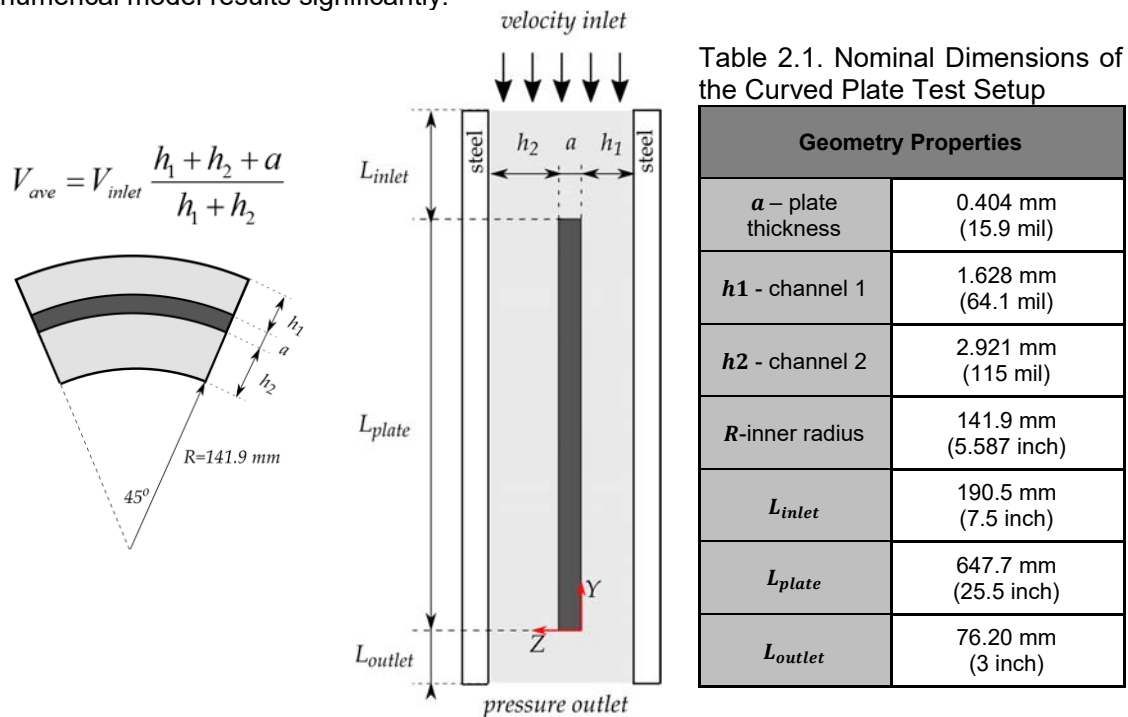

Fig 2.3. Test Section (left) Top View (center) Vertical View - not to scale.

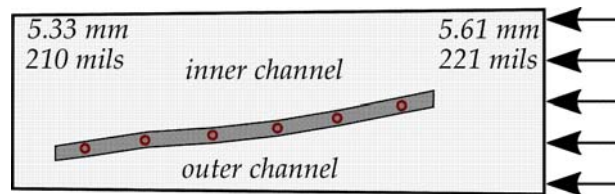

Fig 2.4. Analyzed Plate and Channel Profile used with the As-Fabricated Total Channel Gap in the Upstream Plenum and Downstream Plenum Indicated- not to scale.

### 3 Numerical Models

From the numerical analysis point of view, the behavior of the fuel plate in the flow of coolant

is referred to as Fluid Structure Interaction (FSI). In FSI, the structure deformation due to the flow of fluid significantly influences that flow around it, thus the analysis requires an iterative solution for the steady state results. This work used two different commercially available codes to solve the FSI problem occurring in the analysis of the MURR plate: Star-CCM+ and COMSOL. Historically computational fluid dynamics (CFD) software used for solving fluid flows and computational structural mechanics (CSM) software used for solving the deformations and stresses in solid bodies were developed independently. It naturally led to using a partitioned approach for solving FSI problems, where the equations are solved iteratively one domain (solid - plate or fluid - coolant) at a time and coupling boundary conditions are exchanged between the solid and fluid domains within each iteration. COMSOL uses the Finite Element (FE) method for solving systems of PDEs for both the fluid and the structural problems. As a result of this, COMSOL offers two types of coupling methods for FSI problems. The first is the integrated solver (or fully coupled monolithic solver), and the second is the segregated solver (or partitioned solver). In the monolithic approach to FSI solution the fluid and solid equations become a part of one system of equations and are solved at the same time. This approach, although more accurate, comes with the price of increased needs for large amounts of RAM and decreased stability of the solution.

As a second approach, STAR-CCM+ was used with its Finite Volume (FV) fluid and structural solvers and internal coupling between them. Both approaches allow for keeping the entire simulation within one computational environment. However, the FV implementation only works in the partitioned (iterative fluid-structural) mode and is very CPU intensive and limited to linear elasticity problems. A mesh morphing technique is used by Star-CCM+ and COMSOL simulations to account for the deformation of the plate due to the pressure differentials. It stretches the mesh in the entire fluid region surrounding the plate in a way that high quality mesh is maintained and the mesh deformations are distributed over larger areas. The geometry and the initial conditions for the simulations were assumed based on the experimental test setup described in section 2. For the structural properties of the plate, typical properties of aluminum were used: density of  $2700 \text{ kg/m}^3$ , Young's Modulus of  $68.0 \text{ GPa}$ , and Poisson's Ratio of  $0.33$ .

FV approach for structural mechanics requires as uniform (near cubical) cells as possible and conformal mesh on solid-fluid interface. For that reason, the FV simulations in Star-CCM+ required between 8 to 10 million cells depending on the analyzed case. The velocity of the water flow in the channels affects the convergence speed of the simulations. The higher the flow velocity the longer the simulation run. While the COMSOL simulations can be run on one powerful compute node, the Star-CCM+ FV simulations were run on up to 10 high performance computing cluster nodes (16 cores each, 160 cores in total) for several days in order to obtain a converged solution for the highest flow velocities.

The sensitivity of the model to the turbulence model choice was investigated as well. The study indicated that the selection of the turbulence model does not affect the results significantly, and thus for the remainder of the simulations reported in this paper the k-epsilon turbulence model was used. A mesh sensitivity study was carried out and the outcome of it is presented in the report [2]. The results presented here are only based on the most optimal models. The initial simulations for the ideal curved plate have indicated a highly localized deformation of the plate near the leading edge of the plate. To increase the simulation convergence rate, a variable mesh density models have been built with the densest mesh around the leading edge and coarser mesh away from it. A detail of the mesh used in Star-CCM+ simulations of the curved plate is shown in Figure 3.1.

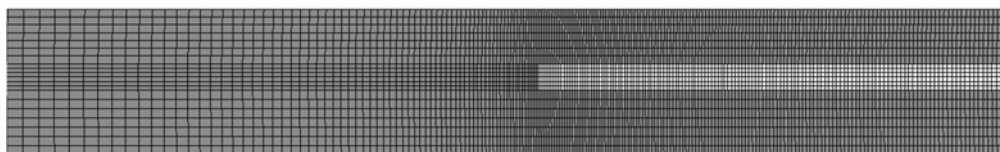

Fig 3.1. Mesh Details for Finite Volume in Star-CCM+ Approach.

Initial simulations were performed for the ideal geometry of the channels and the plate instead of using the as-built measured dimensions. The magnitude of the calculated deflection was not in good agreement with the experimental results. The discrepancy indicated that the ideal geometries modeled are missing an important aspect of the physics or experimental setup. Thus, modeling of the as-built geometries followed. It was concluded that in the case of the curved plate, the imperfections can be mostly accrued in the plate's shape and orientation in respect to the channel walls which were fabricated out of about 6 mm (0.25 inch) thick steel. Since the as-built shape was determined at discrete locations along the center line of the plate, through the Plexiglas windows, analyses across a range of possible variations in geometry have been made. These analyses included azimuthally ununiform as well as non-uniform cross sections. Since the as-built shape of the plate was measured in discrete locations, a piecewise linear fit has been performed to that data. The resulting surfaces were used to directly build the geometry and the mesh of the model.

## **4 Results and Discussion**

### **4.1 Curved Plate Experimental and Numerical Results**

The primary measured quantity in the experiments was plate deflection. Due to the highly localized deformation, even for the thinner plate with thickness 0.404 mm (15.9 mil), only the deflection at the leading edge had any significant magnitude. As simulated, the deflections through the installed Plexiglas windows downstream from the leading edge remain within the range of 0.01 – 0.02 mm (0.4 – 0.8 mil). Since this is at the scale of ~10 micrometers, this approaches the limits of accuracy of the measuring devices. Thus, the most relevant aspect of the experiment is the maximum deformation occurring at the leading edge of the plate.

The simulations are presented for the water flow velocities of 2.0 to 4.0 m/s. Experimental data were gathered at somewhat higher velocities without any change in the type of behavior, however, substantially beyond that velocity range the plate was excessively deforming in models causing the simulation to terminate due to numerical errors. Figure 4.1 presents the deflection of the as-built curved 0.404 mm (15.9 mil) thick plate as obtained from the Star-CCM+ simulations for velocities of 3 m/s and 4 m/s. The maximum deflection was ~0.11 mm (4.3 mil). Figure 4.2 presents the comparison of the numerically obtained maximum deflections for the curved 0.404 mm (15.9 mil) thick plate with the experimental data. Experimental fits were built based on a fifth-order polynomial fit to the measured data. In the same manner, the upper bound of the uncertainty of the measurement was fit. Both computational methods (Star-CCM+ and COMSOL) were in a good agreement with each other and with the experimental data fit. Depending on the numerical tool the maximum deflection of the plate for 4 m/s flow was predicted to be in the range between 0.11 and 0.12 mm (4.3 and 4.7 mil), with the experimental measured deflection around 0.11 mm (4.3 mil).

No significant vibrations were observed in the experiment at any tested flow velocities. This is notable since numerous previous studies have considered the impact of fluid flow on nuclear reactor fuel plates. Some have focused on analytical solutions of plate instabilities such as buckling when in proximity to a critical velocity [3]. Work towards the ANS Reactor design concluded that analytical solutions of deflection were difficult where boundary conditions were complex and subject to variation in both space and time [4], and summarized the main engineering impacts on deflections rather than vibration observed at nearly 2.0 times the Miller critical velocity. Others have focused on the dynamic phenomena of vibration by measuring or modeling what has been termed flow-induced vibrations (FIV) such as that induced by eddies or vortices. In these FIV references there have been studies of multi-plate systems atypical of fuel elements in terms of the support of the plate [5], where a leading plate causes an FIV wake effect on a trailing plate [6], or where fluid flow is not present [7]. These boundary conditions do not however apply to MURR or typical parallel plate-type MTR reactors. In any event, the FSI models in the present work were compared to physical data, and the absence of: vibrations on the scale of the measured deflection, "lock-in" type phenomena leading to plate contact and buckling, or plastic deformation clearly indicates that deflection dominates at relevant conditions (see Section 4.2 for a prototypic plate beyond design velocity).

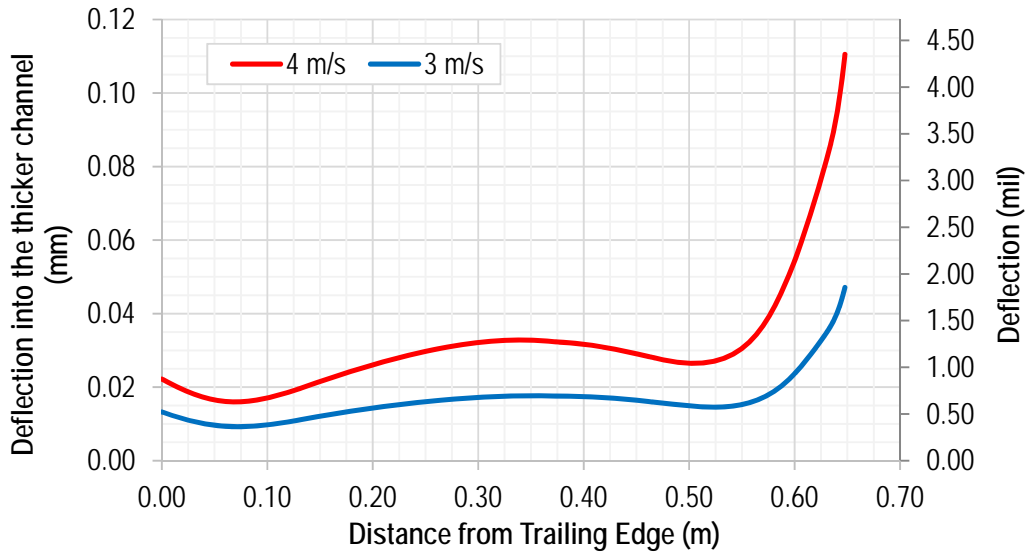

Fig 4.1. Deflection of the 0.404 mm (16 mil) Thick Curved, As-Built Azimuthally Uniform Plate.

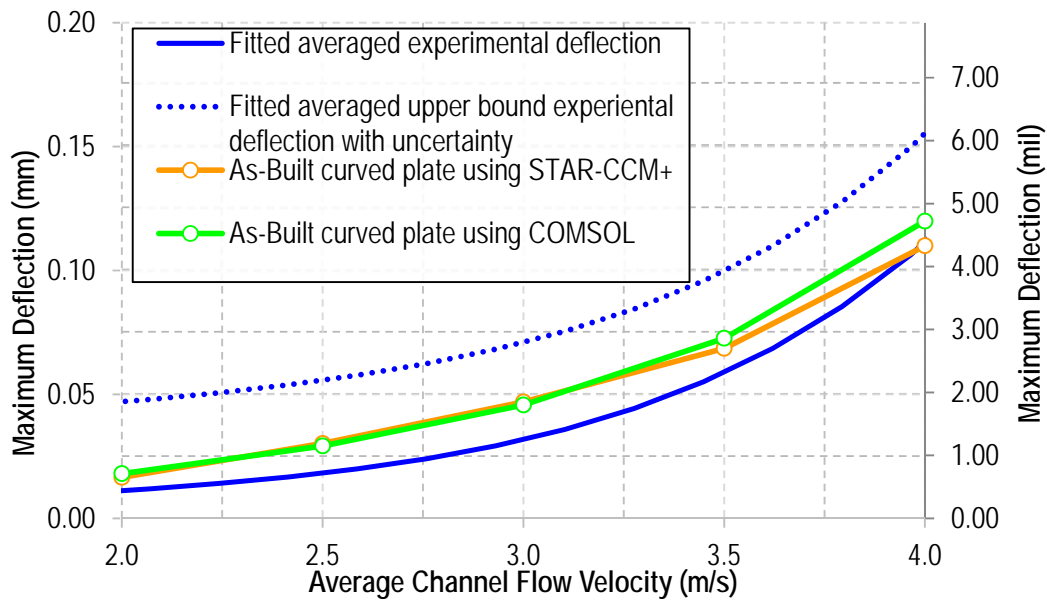

Fig 4.2. Comparison of Maximum Deflection of the Plate for As-Built Cases Obtained with Different Solvers with the Experimental Results.

## 4.2 Curved Prototypic Plate Numerical Results

The most limiting plate in the MURR LEU element from an FSI perspective is Plate 22, which is the fuel plate before the last and outermost one. All of the plates have a thickness of  $1.118 \pm 0.051$  mm ( $44 \pm 2$  mil), except the last, whose thickness is  $1.245 \pm 0.051$  ( $49 \pm 2$  mil). Plate 22 is the most limiting because it has the longest arc length of the thinnest type of plate. A detailed geometry description of the plate geometry can be found in References [2] and [8].

For the prototypic plate simulation results were generated and are summarized here. For the analysis it was decided to construct a conservative geometrical model given the range of possible dimensions that assumes:

1. Plate 22 was at the minimum allowed thickness of 1.067 mm (42 mil).
2. The 0.051 mm (2 mil) reduction from the nominal thickness would be obtained by reducing the fuel meat by 0.025 mm (1 mil) and each aluminum cladding



layer by 0.013 mm (0.5 mil).

3. The channel on the concave side of the plate is to have the gap thickness increased to the maximum allowed by the tolerance and the channel on the convex side of the plate is to have the thickness reduce to the minimum allowed by the tolerance. The thickness of each of these channels is  $2.362 \pm 0.203$  mm ( $93 \pm 8$  mil) [8]. Thus, the thickness of the inner channel is 2.565 mm (101 mil) and the thickness of the outer channel is 2.159 mm (85 mil).

The average channel velocity of 7.1 m/s to be used in the FSI analysis was determined by dividing the maximum core volumetric flow rate by the core flow area. Using a conservative hot channel factor of 1.23 [9], the velocity was increased to 8.7 m/s in the most limiting case.

Numerical models of the MURR LEU Plate 22 were built for Star-CCM+ simulations using the techniques validated on the flat 1.016 mm (40 mil) thick and curved 0.404 mm (15.9 mil) thick plates (see [2]). The overall number of computational cells in the model was around 9.4 million. The simulations converged relatively fast because the deflection of the plate was small. Figure 4.3 presents the deflection profile of the plate. The profile resembles the ones registered for the ideal plates of 0.404 mm (15.9 mil) thickness. The maximum plate deflection, which is located at the center of the leading edge, is less than 0.005 mm (0.2 mil) and is much less than this value over almost all of the plate area. This maximum deflection is extremely small compared to a manufacturing channel gap thickness tolerance of  $\pm 0.203$  mm ( $\pm 8$  mil). Perhaps, of even greater significance is that the plate deflection is towards the larger channel, which tends to enlarge the thickness of the smaller channel and would tend to improve any thermal-hydraulic considerations caused by the different channel thickness. Based on these observations, the effect of plate deflection due to FSI on fuel element thermal-hydraulic and structural performance is insignificant, and is far less than allowances in the PSAR for change in coolant channel thickness.

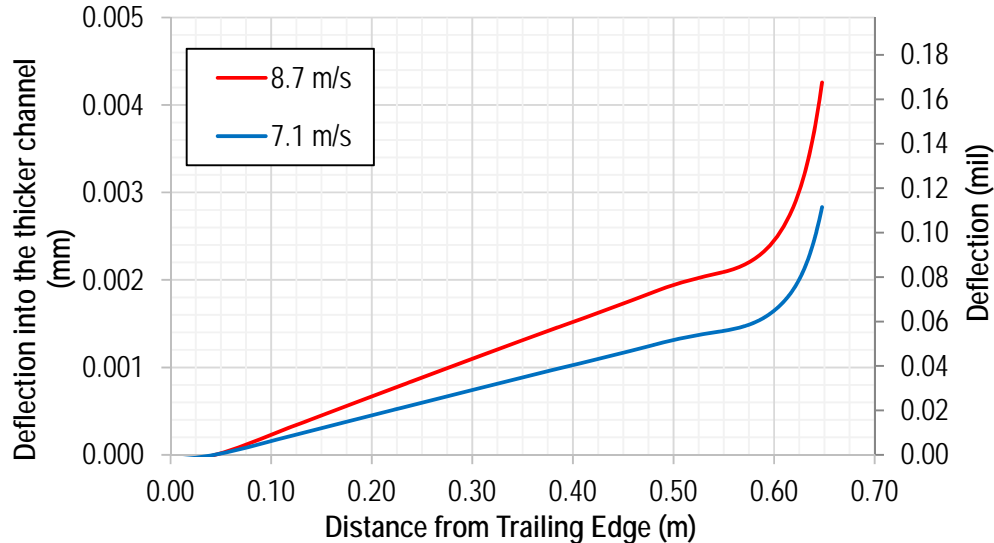

Fig 4.3. Deflection of the Middle of the Plate in the Simulations of Prototypic Plate 22.

## 5 Conclusions

As a part of the work supporting the Preliminary Safety Analysis Report (PSAR) [8] submitted to the NRC by the University of Missouri Research Reactor (MURR), the impact of LEU fuel plates that are thinner (1.12 mm) compared to the HEU fuel plates (1.27 mm), has been assessed. The presented study shows that the available computational tools are able to predict the FSI phenomenon for the experiments analyzed and can be used for the analysis of plate deflection in fuel assemblies. However, the agreement between the simulations and the experiments was only possible with proper modeling of as-built geometrical conditions shown

in previous flat [1], [2] and the present curved plate experiment and modeling.

Two different numerical tools have been used in this work: Star-CCM+ and COMSOL. The results obtained with the use of these tools were in close agreement with each other as well as the experimental results. Each of the techniques has different computation needs, numerical advantages and disadvantages that were discussed in detail in Reference [2].

The most important finding of this work is the deflection of the prototypic MURR LEU 22 plate under both nominal and conservative flow conditions. It was found that the deflection due to fluid-structure interaction is extremely small, on the order of 5 micrometers (0.2 mil) in all cases despite the thinner plate used in the LEU fuel element design. This magnitude of deflection, and the absence of vibration at even this small size scale, supports the conclusion that there is no significant effect on fuel element thermal-hydraulic and structural performance caused by even the bounding fluid velocity.

## 6 Acknowledgements

The authors would like to thank the staff of the Missouri University Research Reactor (MURR) at the University of Missouri Columbia for supporting conversion efforts including providing feedback and guidance during this work.

The authors would also like to acknowledge the expertise of Jim Morgan in the Engineering Operations group of the Nuclear Engineering Division at Argonne National Laboratory. Mr. Morgan was instrumental in the fabrication of the curved test plate and railing system and without his inventive methods for assembly of the curved plate into the narrow annulus of the test section this work would not have been possible.

This work was sponsored by the U.S. Department of Energy, Office of Material Management and Minimization Office of Conversion in the U.S. National Nuclear Security Administration Office of Defense Nuclear Nonproliferation under Contract DE-AC02-06CH11357.

## 7 Bibliography

- [1] J.C. Kennedy, C.J. Jesse, G.L. Solbrekken, "Experimental Investigation of Deflection of Flat Aluminum Plates Under Variable Velocity Parallel Flow (TDR-MU-201404-001C)," University of Missouri, Columbia, USA, 2014.
- [2] A. Tentner, C. Bojanowski, E. Feldman, E. Wilson, G. Solbrekken, C. Jesse, Rivers, J. Rivers, G. Schnieders, "Evaluation of Thin Plate Hydrodynamic Stability through a Combined Numerical Modeling and Experimental Effort, ANL/RTR/TM-16/9," Argonne National Laboratory, Argonne, USA, 2017.
- [3] D.R. Miller, "Critical flow velocities for collapse of reactor parallel-plate fuel assemblies," KAPL-1954, Knolls Atomic Power Laboratory, Schenectady, USA, 1958.
- [4] Swinson et al., "Follow-up Fuel Plate Stability Experiments and Analyses for the Advanced Neutron Source," ORNL/TM-12629, Oak Ridge National Lab., Oak Ridge, USA, 1993.
- [5] Yang et al., "Experimental investigation on fluid–structure interaction phenomenon caused by the flow through double-plate structure in a narrow channel," *Nuc Eng Design* **248** 66-71.
- [6] Latimer et al., "Vibration Analysis of Advanced Test Reactor Mini-Plate Hydraulic Test in the OSU HMFTF," *Trans. ANS* **115** 1542-45.
- [7] T.K. Howard, W.R. Marcum, W.F. Jones, "An Investigation of the Dominate Plate Modes from End Excitation," *Trans. ANS* **115** 1736-9.
- [8] J. Stillman et al., "Low-Enriched Uranium Conversion Preliminary Safety Analysis Report for the University of Missouri Research Reactor," University of Missouri Research Reactor, Columbia, USA, 2017.
- [9] J.A. Stillman, E.E. Feldman, E.H. Wilson, L.P. Foyto, K.Kutikkad, J.C. McKibben, N.J. Peters, W.M. Cowherd and B. Rickman, "Accident Analyses for Conversion of the University of Missouri Research Reactor (MURR) from Highly-Enriched to Low-Enriched Uranium," ANL/GTRI/TM-14/5 R1, Argonne National Laboratory, Argonne, USA, 2017.